



# design brief

## AIR CONDITIONING & VENTILATION

### Summary

Air-conditioning and ventilation systems have a large impact on building profitability. Not only do they consume about 33 percent of an office building's electricity, but they have a large influence on worker productivity. Nonetheless, considerable evidence indicates that air-conditioning systems receive less attention than they deserve. Opportunities to cost-effectively improve the energy efficiency of these systems frequently are overlooked, and surveys of office workers have shown that one-third to one-half of those questioned find their offices too hot or too cold.

This state of affairs is both unnecessary and uneconomical. Using a whole-systems approach, designers around the world have succeeded in crafting highly efficient air-conditioning systems that also provide excellent workspace comfort. Designers begin by minimizing unwanted heat gains to reduce cooling loads. Next, they design air-distribution systems and cooling plants to meet those reduced cooling loads, taking advantage of both capital and operating cost savings. Finally, they specify highly efficient cooling plants.

In one exemplary building that benefited from this approach, worker productivity improved by 16 percent, while electricity consumption decreased by 40 percent. Another building's clever design made it possible to maintain thermal comfort in a hot climate without any electrically powered air-conditioning and ventilation system. Designers need not feel pressured, however, to produce such extraordinary results. Virtually any air-conditioning and ventilation design can be incrementally improved through the use of a whole-systems problem-solving approach.

### A WHOLE-SYSTEMS APPROACH TO INCREASING EFFICIENCY

#### CONTENTS

<a href="#">Introduction</a>	2
<a href="#">Reducing Cooling Loads</a>	5
<a href="#">Improving the Efficiency of Air-Distribution Systems</a>	8
<a href="#">Choosing High-Efficiency Unitary Equipment</a>	11
<a href="#">Designing High-Efficiency Chilled Water Systems</a>	15
<a href="#">Replacing Refrigerative Cooling with Evaporative Cooling</a>	20
<a href="#">Air-Conditioning, Ventilation, and LEED</a>	24
<a href="#">For More Information</a>	26
<a href="#">Notes</a>	28

## Introduction

Air-conditioning and ventilation systems have a tough assignment. Although they work tirelessly to make buildings comfortable and healthy, they are rarely noticed unless they aren't working well. That's a shame, because these systems have a huge impact on the bottom line for building owners and operators. For example, air-conditioning and ventilation systems consume approximately 33 percent of the electricity used in commercial buildings nationally.<sup>1</sup> Although the minimum efficiency of these systems is prescribed by local and national codes and standards—such as the California Energy Commission's Title 24 (“Energy Efficiency Standards for Residential and Nonresidential Buildings”)—there are often many economically justifiable opportunities for reducing air-conditioning energy costs that are overlooked.

The impact that air-conditioning systems have on worker productivity is also frequently overlooked by owners and operators. As **Figure 1** shows, in a single year, office-workers' salaries

**Figure 1: Annual operating costs in dollars per square foot for a medium-size office building**

In a midsize office building, one year's worth of office-worker salaries is roughly equivalent to one-and-one-half times the entire cost of constructing the building.

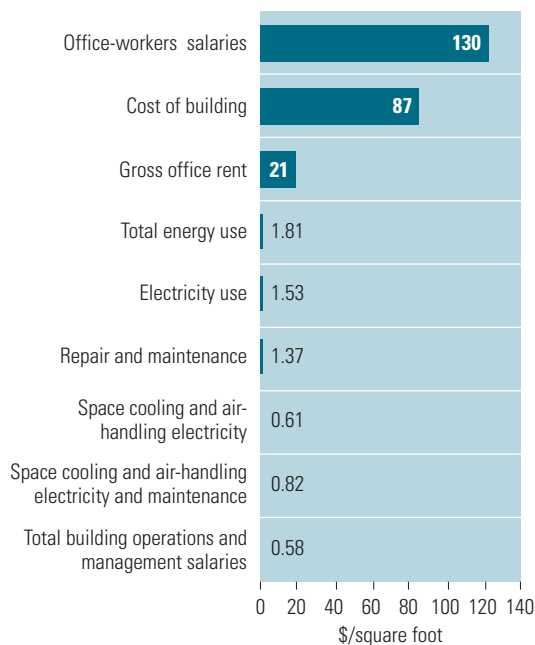

Courtesy: Platts

equal about \$130 per square foot (ft<sup>2</sup>). That is about one-and-one-half times the cost of constructing the building, nearly 100 times the annual electric bill, and about 160 times the operating cost of the building's space-cooling and air-handling system.<sup>2</sup>

Is it worthwhile to spend more money on a high-quality air-conditioning and ventilation design that yields a more comfortable building and improved worker productivity? Judging from studies showing that one-third to one-half of office workers questioned find their offices to be too hot or too cold, the answer would appear to be yes.<sup>3</sup> Productivity gains need not be large to quickly pay for the additional design and construction costs of improving these systems. For example, let's assume that a new commercial air-conditioning system costs about \$10 per ft<sup>2</sup> to design and install. If a 10 percent increase in the cost of that system resulted in only a 1 percent increase in productivity, the additional cost would be paid back sometime during the first year of operation. A 2004 study by Cornell University indicates that the payback could be even quicker. This study found that raising the office temperature from 68° to 77° Fahrenheit (F) increased typing performance and decreased errors. This saved about \$2.00 per hour per worker in lost productivity. The productivity savings amount to over 12 percent.<sup>4</sup>

Because productivity improvements have the potential to yield far greater returns than energy-efficiency improvements would, we also need to ask whether it might make sense to improve productivity at the cost of increased energy consumption. If one had to choose between these two attributes, the obvious choice would be productivity. Fortunately, building designers do not have to settle for that kind of trade-off. It is possible to design highly efficient air-conditioning systems that also provide excellent workspace comfort, yielding lifetime economic benefits for owners and well-modulated temperatures for occupants.

For example, when the West Bend Mutual Insurance Co. built its new 150,000-ft<sup>2</sup> headquarters in West Bend, Wisconsin, several

If you were forced to choose between improving productivity and improving energy efficiency, the obvious bottom-line choice would be productivity. Fortunately, designers do not have to settle for that kind of trade-off.

years ago, the building design incorporated many energy-efficient features, such as upgrades to lighting and window systems. The finished, all-electric building uses 40 percent less electricity than West Bend's old building, which was heated by gas.<sup>5</sup>

But the savings don't end there. The advanced air-conditioning system designed for the building also includes "personal environment modules" for 430 of West Bend's 500 employees. The modules feature adjustable desktop diffusers that allow employees to control both the airflow and the temperature right at their desktops (**Figure 2**).<sup>6</sup> Before and after the move, researchers monitored the performance of West Bend's workers. Overall productivity improved by 16 percent after workers moved into the new building. To determine what portion of that improvement was due to the personal environment modules, researchers turned off some of the modules at random and continued monitoring. The results indicated that the personal environment modules were responsible for a 2.8 percent gain in productivity, worth about \$364,000 per year to West Bend—which was enough to pay for the modules in just 18 months.

**Figure 2: A personal environment module**

Johnson Controls Personal Environment Module allows users to adjust desktop air temperature and airflow by way of a fan-powered mixing box located beneath the desk. The box draws chilled air from the floor plenum or from a vertical chase and passes it through an optional electrostatic filter to adjustable desktop diffusers. An optional electric radiant panel provides heating when needed, and an infrared occupancy sensor mounted on the desktop controller turns off the module's task lighting and other functions after the space has been unoccupied for 10 minutes.

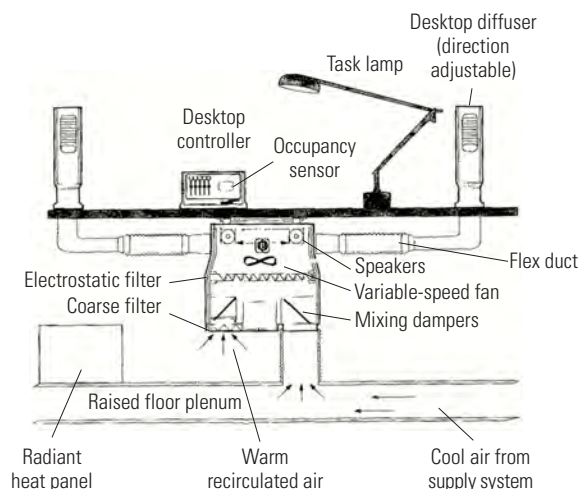

Courtesy: Johnson Controls [6]

Building designers can achieve high levels of comfort and energy efficiency with or without such modular environments. However, to get the best results designers must be willing to start with the objective—in this case, a comfortable and efficient workspace—and then move upstream through the possible systems, selecting the best technologies for reaching that goal. For example, a designer might first reduce cooling loads by minimizing unwanted heat gains. Next, the efficiency of air-distribution systems might be improved, and last, the designer might specify highly efficient cooling plants—or achieve even greater savings by replacing refrigerative cooling with evaporative cooling.

Although this whole-systems integrated design approach is a departure from business as usual, it is not so complicated; any designer could benefit from approaching problem-solving in this way. Once mastered, the whole-systems integrated design approach gives designers an edge that will clearly distinguish them from more conventional competitors who seek only to meet minimum standards and who follow conventional rules of thumb.

## Reducing Cooling Loads

The least expensive way to cut cooling costs for a building may be to not introduce unwanted heat into it in the first place. During the cooling season in many commercial buildings, most of the electricity used to power lights generates heat that must ultimately be carried away by the air-conditioning and ventilation system. If ordinary lighting systems are replaced with more-efficient ones, less electricity is needed to power the lighting system, and therefore less heat is given off, lightening the load for the cooling system.

Once cooling loads have been reduced, an air-conditioning designer may be able to specify a smaller, less-expensive cooling system, reducing operating costs even further. Such a system would feature a smaller cooling plant, but often the designer can also specify smaller pipes, fans, and pumps. These savings may, in turn, offset any additional costs associated with installing the technologies that lightened the cooling load.

Although the whole-systems integrated design approach is a departure from business as usual, it is not so complicated; any designer could benefit from approaching problem-solving in this way.

In some buildings scattered around the world, designers have created extraordinary examples of what can happen when cooling loads are cost-effectively reduced and air-conditioning systems are designed to meet those reduced loads. These clever designs allow thermal comfort to be maintained without any electrically powered air-conditioning and ventilation system at all (**Figure 3**).<sup>7</sup> Certainly, such results will not always be appropriate or even feasible, but these remarkable buildings show what can be accomplished through the use of this innovative design philosophy.

**Figure 3: Passively ventilated and cooled building in a hot climate**

A brewery on the island nation of Malta uses thermal mass, layered construction, and convective ventilation to maintain comfortable core temperatures in a hot climate without an electronically powered air-conditioning and ventilation system. The temperature traces show three days of operation interior air temperatures vary only by about 2°F, and interior surface temperatures change even less.

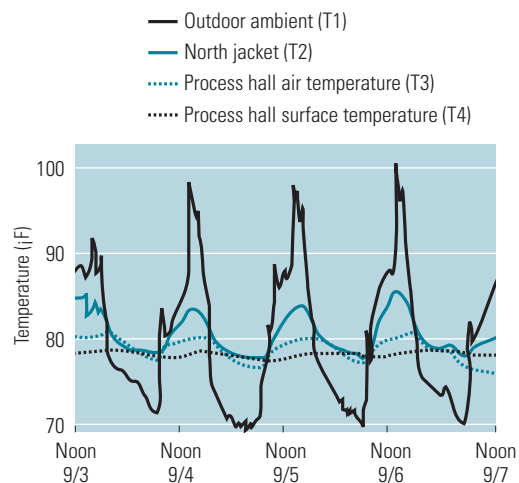
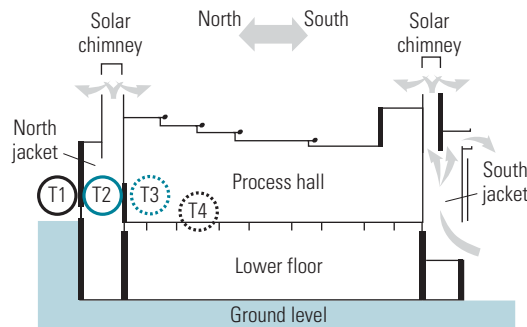

Notes: F = Fahrenheit; T = temperature.

Courtesy: Short and Associates [7]

In addition to improving the efficiency of lighting systems, other strategies that might be employed to reduce cooling loads include (see **Figure 4**):

- Carefully designing the building's form and orientation to maximize daylighting and natural ventilation while minimizing unwanted solar gain and reducing the use of electric lighting.

**Figure 4: Strategies for reducing cooling loads**

This representative commercial building displays a variety of techniques for reducing cooling loads, including roof-wetting to lower temperatures through evaporative and radiative cooling.

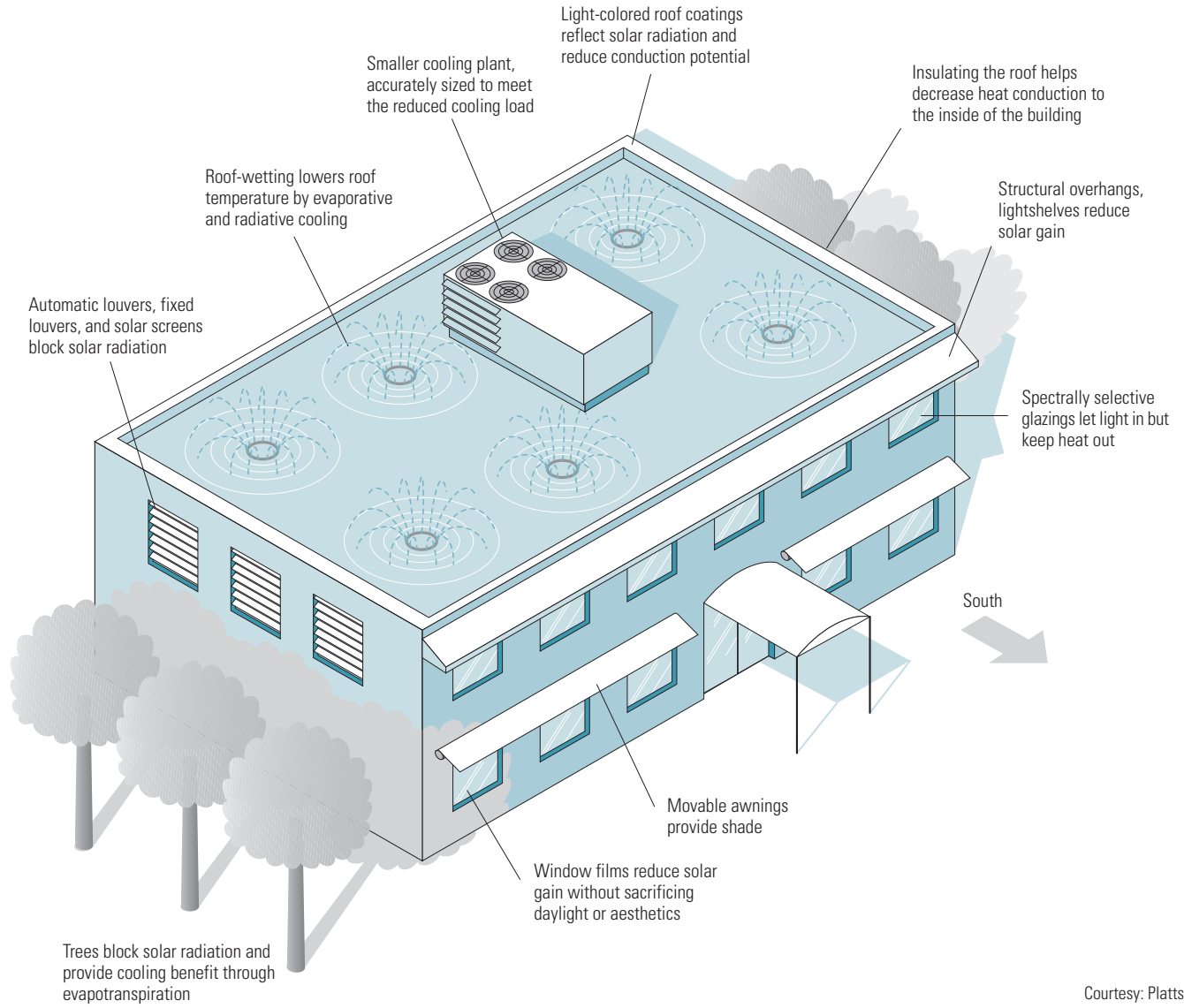

Courtesy: Platts

For the Harmony Library, built in the late 1990s at the Front Range Community College campus in northern Colorado, demand charges were cut in half and energy costs were reduced by 35 percent compared to similar buildings by managing cooling loads.

- Selecting heat-reflecting envelope materials, including window shading, advanced solar-control glazings, insulation, venting, louvers, and light-colored facades and roofs.
- Planting trees and other vegetation to block unwanted sunlight.

To gain the full benefits of these strategies, designers must accurately size the cooling systems of any building in which these strategies are to be implemented.

How much impact can reducing cooling loads and accurately sizing air-conditioning systems have? For the Harmony Library, built in the late 1990s at the Front Range Community College campus in northern Colorado, demand charges were cut in half and energy costs were reduced by 35 percent compared to similar buildings by using many of the methods mentioned above. Diffuse daylight is brought into the building and focused on the ceiling to provide interior lighting without a lot of direct solar heat gain during the cooling season. In addition, windows that provide views to occupants have low-transmittance glazings to reduce glare and heating loads and to strike a visual balance between indoor and outdoor lighting levels (a bright exterior will often cause people to turn up indoor lighting to reduce contrast levels, even when interior light levels are adequate). Overhangs are also used to fully or partially block high-angle sunlight. Because these measures reduce cooling loads, the chiller was able to be downsized, and the building cost no more to build than a conventional one.<sup>8</sup>

### **Improving the Efficiency of Air-Distribution Systems**

Air-distribution systems bring in fresh outside air to disperse contaminants, to provide free cooling, to transport heat generated or removed by space-conditioning equipment, and to create air movement in the space being conditioned. About 30 percent of the energy consumed by air-conditioning systems is used to power the fans that drive air distribution.<sup>9</sup> In California, Title 24 sets maximum limits for the amount of power that can be consumed by



air-distribution fans, but it is entirely possible to design systems that consume far less power. Again, a designer following the whole-system integrated design approach would begin downstream and work through the system, in the following sequence:

1. *Minimize airflows.* Accurately determine cooling and outside air requirements, and specify variable air volume (VAV) controls that continuously adjust the volume of supply air to building loads. Also, buildings that have long operating hours, widely varying and unpredictable occupancy, and at least moderate heating or cooling loads can benefit from demand-controlled ventilation. Minimizing airflows links the amount of outside air drawn in to the actual occupancy of the building at any given time. This can reduce both the fan energy needed to ventilate and also the energy used to heat or cool outside air.
2. *Minimize the friction of distribution system components.* Mechanically delivered air must cover a lot of territory before it reaches a building occupant, winding its way through filters, cooling coils, silencers, ducts, dampers, and diffusers. Select components that offer low pressure drop wherever it will be cost-effective. For example, doubling the diameter of a duct reduces its friction by a factor of  $2^5$ , so that the friction becomes one-32nd of its original value.
3. *Specify high-efficiency fans.* With total efficiency ratings of 70 to 80 percent, the most efficient fans are well-designed axial units and backward-curved centrifugal models. Although widely used, forward-curved fans are much less efficient (**Figure 5**).

Much of the energy consumed to drive fans turns into heat that must ultimately be removed from the building by the cooling system. When an air-distribution system is made more efficient, the fan will consume less energy and the cooling load will also be reduced. This compounding of savings may add as much as 23 percent to the direct fan savings.<sup>10</sup>

**Figure 5: Centrifugal fan impeller blades**

Backward-curved airfoil impellers provide the highest efficiencies for centrifugal fans.

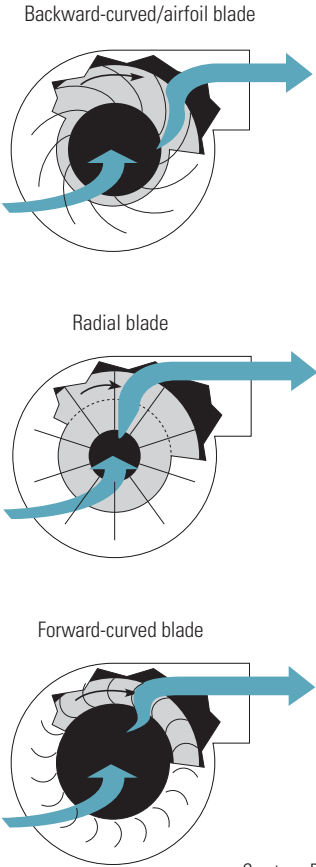

Courtesy: Platts

### Figure 6: Raised flooring

Raised floors look conventional from above, but there is plenty of space for cabling and airflow beneath the 2-by-2-foot structural squares.



Courtesy: Platts

When the Sacramento Municipal Utility District (SMUD) began designing a new 175,000-ft<sup>2</sup> customer service center in the mid-1990s, the district applied the whole-systems integrated design approach. The designers selected an underfloor air-distribution system, which uses a 12-inch gap below raised flooring throughout the office space as the supply-air plenum (**Figure 6**). Underfloor systems offer six major benefits:

- *Reduced fan power.* Although more air flows through underfloor systems, the floor plenum presents far less resistance than ductwork, so the fan doesn't have to work as hard.
- *Higher chiller efficiency.* Underfloor systems use warmer supply air (about 60° to 65°F), allowing for a warmer evaporator temperature, which boosts chiller efficiency.
- *Extended economizer range.* Using warmer supply air significantly extends conditions for free cooling (using outside air directly for cooling, with no chiller operation), especially in mild climates.
- *Better heat removal.* Because underfloor systems provide floor-to-ceiling airflow, most of the heat from ceiling-mounted lights is carried away before it can enter a conditioned space. This reduces the effective cooling load in the conditioned space, allowing warmer air to condition the area.
- *More-effective pollutant removal.* The vertical airflow eliminates lateral air mixing. Pollutants are drawn up in a vertical plume to the ceiling rather than being swirled around with room air.
- *Flexible space arrangements.* The raised floor, with its modular panels, makes it easy to relocate diffusers, wiring, and even plumbing to accommodate changes in occupancy. Dollar savings from this benefit can be more than those from the reduction in energy usage that underfloor systems can provide, depending on how often workspaces are reconfigured.

Given these benefits, one might expect underfloor systems to be considerably more expensive than conventional air-distribution systems, but evidence suggests they are not. A comparison of floor and duct costs from four projects shows construction costs for the two types of systems to be nearly equal. In general, the costs of the raised floor cancel out the savings from not having to build a duct system.<sup>11</sup>

The underfloor system at the SMUD Customer Service Center has paid off. Employees report that the air feels cleaner, and absenteeism has been cut by 30 percent. The utility also saves significant amounts of money every time it reconfigures the workspace. The marginal cost for the system was recouped after the first few moves and, with at least half of SMUD’s employees moving once per year, the savings continue to grow. The underfloor air system was also projected to cut the building’s cooling energy requirements by about 10 percent and fan energy requirements by about 5 percent, but the organization has not tracked the energy savings.<sup>12</sup>

For buildings that use VAV systems, a free design guide is available that can help capture energy savings. The *Advanced Variable Air Volume Design Guide* (<http://energydesignresources.com/Resources/Publications/DesignGuidelines/tabid/73/articleType/ArticleView/articleId/331/Default.aspx>), sponsored by the California Energy Commission Public Interest Energy Research program, was written for HVAC designers and focuses on VAV systems in multistory office buildings. It includes best practices for many system components and provides guidance on integrating the entire air-distribution system.

### Choosing High-Efficiency Unitary Equipment

Take a peek at the equipment that cools nearly any commercial building, and you are likely to see unitary equipment. Available as single packages or as split systems (Figure 7),<sup>13</sup> unitary equipment cools approximately 70 percent of all the air-conditioned commercial buildings in the United States.<sup>14</sup>

**Figure 7: Split and single-package unitary equipment systems**

Split systems are made up of an indoor unit (containing a fan and an evaporator) and an outdoor unit (containing a condenser, a condenser fan, and a compressor). Single-package systems include all functions in one outdoor package.

**Split system**



**Single package**



Courtesy: Trane [13]

There is a lot of choice—manufacturers offer units with a wide range of efficiencies.

The cooling efficiencies of both single-package and split-system unitary air conditioners under 250,000 Btu per hour (Btu/h) are certified according to standards published by the Air-Conditioning and Refrigeration Institute (ARI). ARI standards also apply to units of 250,000 Btu/h and over, but ARI has no certification program and does not publish efficiency data for this size range.

The three cooling-efficiency measurements defined in the ARI standards are EER (the energy-efficiency ratio), SEER (the seasonal energy-efficiency ratio), and IPLV (the integrated part-load value). EER is a ratio of the rate of cooling (Btu/h) to the power input (in watts) at full-load conditions. The power input includes all inputs to compressors, fan motors, and controls. SEER and IPLV are estimated or calculated ratios of annual cooling (in Btu) to the annual energy consumption (in watt-hours [Wh]). SEER is a seasonally adjusted rating based on representative residential loads that applies only to units with a cooling capacity of less than 65,000 Btu/h. IPLV, a seasonal efficiency rating method based on representative commercial loads, applies to units with cooling capacities at or greater than 65,000 Btu per hour. EER is the rating of choice when determining which unit will operate most efficiently during full-load conditions. SEER and IPLV are better than EER for determining which unit will use less energy over the course of an entire cooling season.

Standards set by the federal government require that manufacturers produce equipment at minimum efficiency levels. In addition, the California Energy Commission, via Title 24, establishes minimum efficiency levels for equipment used in California buildings.

**Table 1** and **Table 2** summarize these minimum efficiencies.

When trying to minimize operating costs, the design challenge is to specify the most efficient unit that will fit within a client's cost-effectiveness limits. There is a lot of choice—manufacturers offer units with a wide range of efficiencies that exceed the minimum efficiency ratings across the different sizes of cooling plants.

**Table 1: Minimum efficiency requirements for air-cooled unitary cooling equipment >65 kBtu/h (5.4 tons)**

Two standards impact large HVAC equipment in California. The federal standard applies to manufacturers of HVAC equipment, whereas the California Energy Commission’s Title 24 requirements apply to buildings. The U.S. shipment weighted average efficiency for unitary air conditioners between 65,000 Btu (5.4 tons) and 240,000 Btu/h is 10.1 EER.

Standard	Effective date	65 to <135 kBtu/h (5.40 to <11.25 tons)		135 to <240 kBtu/h (11.25 to <20.00 tons)		240 to <760 kBtu/h (20.00 to <63.33 tons)		≥760 kBtu/h (≥63.33 tons)	
		EER	IPLV	EER	IPLV	EER	IPLV	EER	IPLV
1992 U.S. federal standard	January 1, 1994	8.9	8.3	8.5	7.5	NA	NA	NA	NA
T 24: air conditioners	January 1, 2010	11.2	NA	11.0	NA	10.0	9.7	9.7	9.4
T 24: heat pumps (cooling mode)	January 1, 2010	11.0	NA	10.6	NA	9.5	9.2	9.5	9.2
EPAct: Air conditioners	January 1, 2010	11.2	NA	11.0	NA	10.0	NA	NA	NA
EPAct: Heat pumps (cooling mode)	January 1, 2010	11.0	NA	10.6	NA	9.5	NA	NA	NA

Notes: EER = energy-efficiency ratio; EPAct = Energy Policy Act of 2005; IPLV = integrated part-load value; kBtu/h = thousand Btu per hour; T 24 = California Title 24 Building Energy Efficiency Standards; NA = not applicable.

Courtesy: Platts

**Table 2: U.S. federal standards for air-cooled air conditioners and heat pumps <65 kBtu/h (5.4 tons)**

Though the California Energy Commission’s Title 20, Appliance Efficiency Regulations, gives efficiency specifications for this equipment, the federal standards take precedence.

Effective date	Split			Single packaged		
	SEER	EER	HSPF	SEER	EER	HSPF
January 1, 1992	10.0	NA	6.8	NA	NA	NA
January 1, 1993	NA	NA	NA	9.7	NA	6.6
January 23, 2006	13.0	NA	7.7	13.0	NA	7.7

Notes: EER = energy-efficiency ratio; HSPF = heating season performance factor; kBtu/h = thousand Btu per hour; NA = not applicable; SEER = seasonal energy-efficiency ratio.

Courtesy: Platts

Two main sources of information are available to help designers identify units that exceed the minimum efficiency ratings: ARI and the California Energy Commission. The most widely used references are directories maintained by ARI, which include products from all ARI member-manufacturers. These directories are available in both print and electronic formats. Although the California Energy Commission also maintains a database on its web site, only units with up to 65,000 Btu per hour cooling capacity are listed there.

The Pacific Northwest National Laboratory offers a free web-based life-cycle cost estimation tool that can be used to compare high-efficiency unitary air-conditioning equipment to standard equipment. After a user enters data for a specific unit along with

The costs and efficiency ratings of individual unitary air conditioners vary so widely that the economics of purchasing a high-efficiency unit must be analyzed on a case-by-case basis.

location information, the tool estimates life-cycle cost, simple payback, and other metrics as compared to a standard unit (which is also user-definable).

To manually calculate the potential savings that might be realized with a unit that exceeds minimum efficiency, the designer starts by determining the demand savings that would occur during a peak cooling moment, using the following equation:

$$kW_{\text{savings}} = \text{tons} \times (12/\text{EER}_{\text{minimum}} - 12/\text{EER}_{\text{improved}})$$

where:

kW = kilowatt

$kW_{\text{savings}}$  = demand savings

tons = capacity (12,000 Btu/h = 1 ton)

$\text{EER}_{\text{minimum}}$  = rating of minimum-efficiency unit (Btu/Wh)

$\text{EER}_{\text{improved}}$  = rating of improved-efficiency units (Btu/Wh)

To estimate annual electric energy savings, you will need an estimate of the “annual equivalent full-load cooling hours” (AEFLCH). That’s the number of hours an air conditioner would run at full load to consume the same amount of electric energy it consumes on average over the course of an entire year. Annual equivalent full-load hours are listed in a variety of engineering manuals, including those published by ASHRAE (the American Society of Heating, Refrigerating, and Air-Conditioning Engineers).<sup>15</sup> In southern California, the AEFLCH generally range from about 1,000 to 1,500 hours per year. With an estimate of AEFLCH in hand, annual savings may then be calculated as follows:

$$kWh_{\text{savings}} = kW_{\text{savings}} \times \text{AEFLCH}$$

where:

kWh = kilowatt-hour

$kWh_{\text{savings}}$  = annual electric energy savings (kWh)

The costs and efficiency ratings of individual unitary air conditioners vary so widely that the economics of purchasing a high-efficiency unit must be analyzed on a case-by-case basis. Take, for example, a choice between a 15-ton rooftop unit rated at 9.7 EER

and another rated at 10.8 EER. Let's say that the high-efficiency unit costs about \$725 more than the minimum-efficiency unit. During peak cooling conditions, the high-efficiency unit would draw 1.9 kW less power, and assuming 1,500 AEFLCH, it would save about 2,850 kilowatt-hours (kWh). At an average electricity cost of 8.2¢/kWh, annual savings would be, on average, about \$234 per year, yielding a simple annual payback period of three years.

### Designing High-Efficiency Chilled Water Systems

Chilled water systems feature separate central chillers and air handlers, with a network of pipes and pumps to connect them. These systems are mainly found in large buildings. Although only 19 percent of all commercial building floorspace in U.S. buildings is cooled by chillers, at least in part, approximately 44 percent of all buildings larger than 100,000 ft<sup>2</sup> contain chilled water systems.<sup>16</sup>

By their nature, chilled water systems are complex (**Figure 8**), so it is not surprising that they present a cornucopia of efficien-

**Figure 8: Conceptual view of a chilled water air-conditioning system**

In this figure, thermal energy moves from left to right as it is extracted from the space and expelled into the outdoors through five loops of heat transfer:

- ¥ **Indoor air loop.** In the far left loop, indoor air is driven by the supply air fan through a cooling coil, where it transfers its heat to chilled water. The cool air then cools the building space.
- ¥ **Chilled water loop.** Driven by the chilled water pump, water returns from the cooling coil to the chiller's evaporator to be re-cooled.
- ¥ **Refrigerant loop.** Using a phase-change refrigerant, the chiller's compressor pumps heat from the chilled water to the condenser water.
- ¥ **Condenser water loop.** Water absorbs heat from the chiller's condenser, and the condenser water pump sends it to the cooling tower.
- ¥ **Cooling tower loop.** The cooling tower's fan drives air across an open flow of the hot condenser water, transferring the heat to the outdoors.

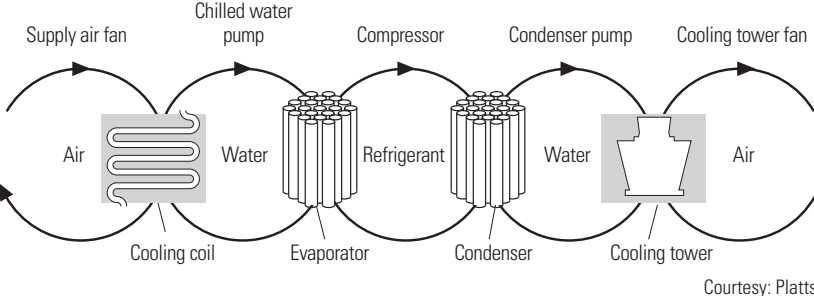

Courtesy: Platts

Although Title 24 sets minimums for chillers, a lot of equipment is available with higher efficiency ratings.

cy opportunities. Designers who think their way upstream through these systems, starting at the cooling coil and ending at the cooling tower fan, are likely to find opportunities to improve efficiency while taking advantage of capital cost savings for upstream components. For example, by reducing resistance within the piping system, a designer might be able to reduce capital costs by specifying a smaller pump and a smaller chiller. The following list presents efficiency opportunities for chilled water systems that should be balanced against capital costs for implementing them, in downstream-to-upstream order:

- *Select cooling coils for low air-side and water-side flow resistance and for low cooling-water flow rates.*
- *Increase pipe diameters and specify low-friction valves to reduce flow resistance for the chilled water.*
- *Specify highly efficient pumps with highly efficient motors.*
- *Control chilled water pumps with adjustable-speed drives.* However, do take precautions to ensure that flow rates through chillers are maintained at safe levels.
- *Specify high-efficiency water-cooled chillers.* Although Title 24 sets minimums for chillers, a lot of equipment is available with higher efficiency ratings. For example, the Title 24 minimum for water-cooled centrifugal chillers that are 300 tons or greater is 0.576 kW per ton at standard full-load conditions, but some of the centrifugal chillers now available operate at 0.470 kW per ton. Given that annual energy costs for a chiller may amount to as much as one-third of their purchase price, even a modest improvement in efficiency can yield substantial energy savings and attractive paybacks. For example, paying an extra \$6 per ton for each 0.01-kW-per-ton improvement to raise the efficiency of a 500-ton chiller from 0.6 kW per ton to 0.56 kW per ton would increase that machine's first cost by \$12,000. But that change would reduce operating costs by \$3,000 per year, yielding a four-year simple payback.<sup>17</sup>



- *Select a chiller that will be most efficient under the conditions it is likely to experience.* Even though chiller performance can vary dramatically depending on loading and other conditions, designers frequently select chillers based on full-load, standard-condition efficiency. However, chillers spend most hours at 40 to 70 percent load, under conditions that are often considerably different from standard conditions. To select the chiller that will have the lowest operating costs, designers need to determine what the actual operating conditions are likely to be and then evaluate the efficiency with which candidate chillers are likely to operate under those conditions.
- *Select unequally sized machines for multiple chiller installations.* Chillers operate more efficiently when they are loaded close to their full rating than when they are only lightly loaded. Under most operating conditions, if one chiller in a two-machine installation is smaller than the other, one or the other of the two chillers should be able to run close to full load. This will result in more-efficient operation than if one or two chillers of the same size were operating at a lighter load.
- *Install a variable-speed drive (VSD) on the chiller compressor.* The VSD will allow the compressor to run at lower speed under part-load conditions, thereby yielding a lower compressor kilowatt-per-ton rating under those conditions than is typically achieved by ordinary centrifugal chillers that control part-load operation with inlet vanes.
- *Specify an induced-draft cooling tower.* Although it requires more space than a forced-draft tower, the induced-draft tower is more efficient.
- *Oversize the cooling tower so that it returns condenser water to the chiller closer to wetbulb temperature.*

Chillers spend most hours at 40 to 70 percent load, under conditions that are often considerably different from standard conditions.

- *Install VSDs to control cooling-tower fans on chilled water systems with multiple manifolded towers or multicell towers.*
- *Install heat exchangers and controls to allow cooling towers to produce chilled water when weather conditions permit.*

There is a pair of serious challenges inherent in a design approach that considers these opportunities. First, it is difficult to generalize about their cost-effectiveness. Selecting the most cost-effective chiller for a particular building often requires a designer to take into account energy and demand prices, building load characteristics, local climate, building construction, operating schedules, and the part-load operating characteristics of the available chillers. Accounting for all these variables can be a daunting task, especially because some of them change on an hourly basis.

Second, although it is tempting to improve the efficiency of chilled water systems by minimizing the energy consumption of each individual component, that approach does not necessarily lead to the most efficient system. The pieces of a chilled water system interact in complex ways that make such general prescriptions difficult. For example, the efficiency of a chiller can be improved by increasing chilled water flow. However, that will necessitate more pumping power, which may exceed the saved chiller power, resulting in a net loss of system efficiency.

To illustrate these challenges, consider the case of a designer who switched a chiller condenser-tube bundle from two-pass flow to four-pass flow in order to improve chiller efficiency. That change improved chiller efficiency from 0.62 kW per ton to 0.60 kW per ton, but it also added 28 feet of pressure drop to the chilled water flow stream and increased the required pumping power by 8.6 kW. At full load, the new tube bundle reduced chiller power by 8.8 kW, but when the increased pumping power was added, overall system power was cut by 0.2 kW. At 75 percent load, which was typical in this building, the new tube bundle reduced chiller power by 6.6 kW. But

because this particular building featured a constant-flow system, the pumping power increase of 8.6 kW led to an overall system power-demand increase of 2 kW. The net effect was even worse at lower loads. Although this designer had intended to reduce energy consumption by improving chiller efficiency, he wound up increasing overall building energy consumption.

In the face of such complexity, how can building designers determine the combination of strategies that will produce an optimal chilled water system? One of the best options is to turn to a building energy performance simulation package. These computer programs perform the numerous and complex equations needed to evaluate how buildings use energy. The most sophisticated programs are capable of calculating building energy consumption hour by hour for an entire year. That allows designers to see how modifications to any of the building's systems—including the chilled water system—will affect the building's annual energy consumption. Furthermore, these packages account for interactions between building components. As a result, building designers can experiment with a variety of combinations of efficiency strategies and determine which ones produce the most cost-effective building.

The best-known hourly simulation software is DOE-2 (developed by the Simulation Research Group at Lawrence Berkeley National Laboratory), but there are several other packages available on the market, a few of which are produced by HVAC equipment manufacturers. It does take some practice to become adept at using these building energy performance simulations, and running a variety of scenarios can be quite time-consuming. Therefore, some designers may prefer to hire consultants who specialize in performing these evaluations. Either way, designers and their clients may seek to amortize the cost of simulating building performance by using simulations after the building is occupied in order to verify savings, optimize HVAC system control, and identify malfunctions in building systems.

One of the best options to produce an optimal chilled water system is to turn to a building energy performance simulation package.

As part of the Saving by Design incentive program offered by California utilities, a free software package is also available that makes it easier to model chiller systems. It is a “window- and wizard-driven” front end to DOE-2 called eQUEST that is used for the “Whole Building Approach” of Savings by Design. It is easier to use than DOE-2, yet it allows users to access DOE-2’s full capabilities to model many variables that will affect a chiller’s performance. It can also be used to assess and help minimize building cooling loads. Savings achieved from the proposed cooling system are compared with a modeled baseline chiller plant set to conform with local building codes.

Also, to provide support for the chiller plant design process, Pacific Gas and Electric sponsored CoolTools (<http://energydesignresources.com/Resources/SoftwareTools/CoolToolstrade.aspx>), a project that creates free educational materials and software tools. One of those products, “The CoolTools Chilled Water Plant Design and Specification Guide,” (<http://www.energydesignresources.com/Technology/HVACDesign/tabid/97/articleType/ArticleView/articleId/422/Default.aspx>), was written for the technical design audience. It offers direction on many of the options available in designing a chilled water plant.

## **Replacing Refrigerative Cooling with Evaporative Cooling**

All cooling systems currently produced for commercial buildings are based on the principle of evaporation. As molecules are energized from the liquid to gas state, they carry away from the liquid the heat of vaporization. In most cooling systems, a refrigerant evaporates within a sealed heat exchanger. In another, albeit less-popular, technology, water simply evaporates into air to produce a cooling effect. Known by the moniker “evaporative cooling,” water-based systems employing this technology typically use less than one-fourth the energy of refrigerative air-conditioning systems. The reason evaporative systems use less energy is that, unlike refrigerative systems, they do not have to compress vapor and condense it back into liquid to repeat the

cooling cycle. Instead, evaporative coolers continually introduce fresh supplies of air and water.

Despite such favorable energy-consumption characteristics, evaporative coolers are rarely found in commercial buildings. In fact, only about 3 percent of all floor space for commercial buildings in the U.S. is cooled, at least in part, by this technology.<sup>18</sup> Why is that so? It may be because evaporative cooling applications are limited by local climate, many HVAC designers are unfamiliar with evaporative technologies, and evaporative cooling systems typically have a higher first cost than refrigerative cooling systems. However, in southern California evaporative cooling is feasible in most inland locations, the technology is rapidly becoming more popular, and any additional first costs are usually returned quickly in the form of energy savings.

There are four types of evaporative cooling systems, and they are listed here in order of complexity and cost:

1. *Direct.* Long used to cool homes and small commercial buildings in the arid American West, direct evaporative coolers (also known as swamp coolers) use a fan to blow hot, relatively dry outside air across a wetted pad (Figure 9). The water evaporates directly into the incoming airstream. To keep the process

**Figure 9: Direct evaporative cooler**

Wet-surface direct evaporative coolers typically use pumped recirculating water systems to keep the media wet and use a fan that blows air through the media, thereby cooling it and increasing its humidity. The arrow indicates that moisture has been added to the airstream.

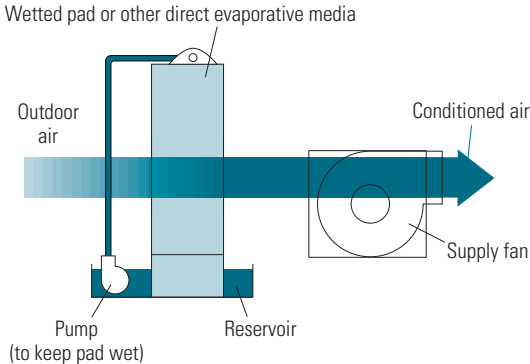

Courtesy: Platts

going, an equal quantity of air must constantly be exhausted from the building to offset the inflow. The chief drawback of direct coolers, at least in moist climates, is that they increase the humidity of the conditioned space.

2. *Indirect.* These coolers feature an impermeable heat-exchange surface such as a thin plastic plate or tube. A direct evaporative process cools air or water on one side of the exchanger so that air passing by the other side of the exchange surface is cooled without any moisture being added (**Figure 10**). Because the cooling capacity of these units is not as great as that of direct evaporative coolers, indirect coolers have traditionally been used only occasionally as stand-alone systems to cool outside-air ventilation intake flows. However, a new indirect technology made by Coolerado, a spin-off of thermodynamic research company Idalex, provides more capacity than standard indirect systems, so it may see more usage as a stand-alone cooler. The water-side economizer is another form of indirect evaporative cooler.
3. *Two-stage.* By placing an indirect cooler upstream from a direct cooler, lower-temperature air can be supplied than is possible with either of these technologies alone (**Figure 11**). Two-stage

**Figure 10: Air-to-air indirect evaporative cooler**

In a typical indirect evaporative air cooler, the essential element is a heat exchanger in which dry air contacts heat exchange surfaces whose other sides are cooled evaporatively. The darker-colored arrow indicates that moisture has been added to the airstream.

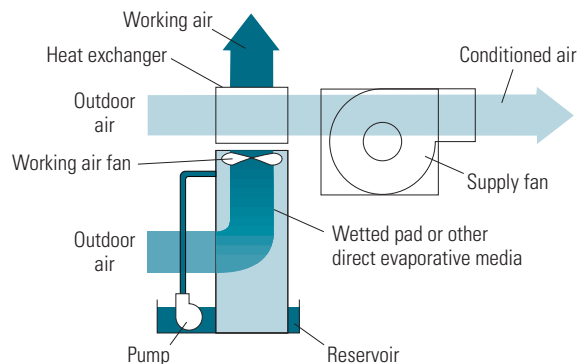

Courtesy: Platts

systems are capable of providing cooling that is equivalent to, or even superior to, refrigerative air conditioners.

4. *Hybrid.* These systems combine evaporative and vapor-compression technology. They use evaporative cooling whenever possible, but they provide vapor-compression refrigeration for additional cooling or humidity control.

To determine whether a two-stage system is capable of meeting peak cooling loads for a particular location, designers need to begin by determining the local summer design wetbulb temperature. This temperature is measured by a thermometer that has a wetted sock stretched over the bulb. Air is allowed to flow over the sock at a specified velocity. The drier the air that passes over the sock, the lower the wetbulb temperature will be. The California Energy Commission publishes summer design wetbulb temperatures for hundreds of locations throughout California.<sup>19</sup> Wherever the summer design wetbulb temperature is below 70°F, a two-stage system is likely to work well nearly all the time. Before making a commitment to such a system, however, designers should also check local weather records to ensure that the location does not experience extended periods of high wetbulb temperatures combined

**Figure 11: Two-stage evaporative cooler**

Dry air leaving the indirect stage can be further cooled in the direct stage to a temperature below the outdoor wetbulb temperature. The darker-colored arrow indicates that moisture has been added to the airstream.

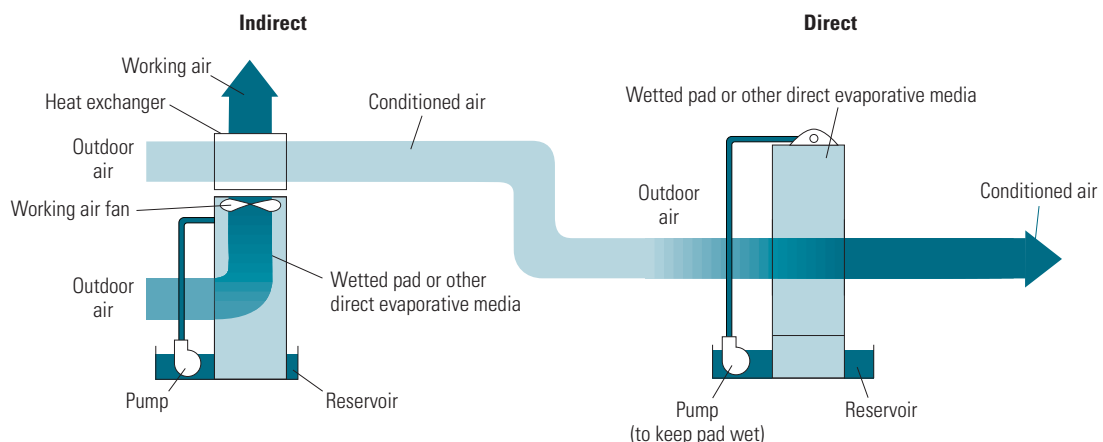

Courtesy: Platts

with high drybulb temperatures. A hybrid system may well be the most cost-effective option for locations that experience conditions exceeding the capabilities of two-stage coolers.

Evaporative cooling systems range widely in cost, depending on the complexity of the design and the materials of construction. It is difficult to compare their costs to those of refrigerative cooling systems, because the cost of evaporative systems is expressed in dollars per cubic feet per minute rather than in dollars per ton. Another complication is that the amount of cooling an evaporative system provides can vary widely depending on local climate. There are, however, numerous examples of systems that have been independently studied and shown to be cost-effective. Take, for example, One Utah Center, a 419,000-ft<sup>2</sup> office tower in the Salt Lake City area. This building features a hybrid system with a two-stage evaporative cooler, oversized cooling towers, refrigerative chillers, economizer ventilation, thermal storage tanks, and variable-flow pumping. Computer models predict annual savings of about 1,700,000 kWh that can be attributed directly to the evaporative cooling system. At the local electric rate of only 3¢/kWh, annual savings would be \$51,000 against an initial added cost for the evaporative cooling system of \$180,000—for a simple payback period of 3.5 years.<sup>20</sup> An equivalent system in a location where electricity cost 9 cents per kWh would pay for itself in just over one year.

## **Air-Conditioning, Ventilation, and LEED**

Air-conditioning and ventilation play a role in the Leadership in Energy and Environmental Design (LEED) system. LEED is a rating system created by the U.S. Green Building Council (USGBC) to accelerate the development and implementation of green building practices. The USGBC is a nonprofit organization founded to promote the construction of environmentally responsible buildings. It established LEED to serve as a brand for high-performance buildings and to provide a common standard for measuring the sustainability, or “greenness,” of a building.



A building earns a LEED rating (certified, silver, gold, or platinum) based on how many points it earns in the following categories: sustainable sites, water efficiency, energy and atmosphere, materials and resources, indoor environmental quality, and innovation and design process. Air-conditioning and ventilation play a role in LEED for a number of the following two categories.

### Energy and Atmosphere (E&A)

- *Prerequisite 1—fundamental building systems commissioning.* Air-conditioning and ventilation systems must be commissioned to function properly.
- *Prerequisite 2—minimum energy performance.* All LEED buildings must meet either the local energy code requirements or the provisions of ASHRAE/IESNA (Illuminating Engineering Society of North America) 90.1-2007. In addition, the more efficient a building is, the more points it will be awarded, up to an additional 19 points. Although air-conditioning and ventilation are not called out specifically, they are crucial to the energy performance of the whole building.
- *Prerequisite 3—Fundamental Refrigerant Management.* For new buildings, specify air-conditioning equipment that uses no chlorofluorocarbon (CFC) refrigerants. For existing buildings, complete a comprehensive CFC phase-out conversion.
- *Credits.* Credits are given for air-conditioning and ventilation systems that help achieve higher building efficiency (credit 1), that are a part of additional commissioning efforts (credit 3), that do not contain HCFCs (hydrochlorofluorocarbons) or halon (credit 4), that use continuous metering equipment (credit 5), and that use green power (credit 6).

### Indoor Environmental Quality

- *Prerequisite 1—minimum IAQ performance.* All LEED buildings must meet the minimum requirements of ASHRAE 62.1-2007: “Ventilation for Acceptable Indoor Air Quality [IAQ]” and approved addenda.

Air-conditioning and ventilation play a role in LEED.

- *Prerequisite 2—environmental tobacco smoke control.* Ventilation systems must prevent exposure of building occupants and systems to tobacco smoke.
- *Credits.* Credits are given for air-conditioning and ventilation systems that use carbon dioxide monitoring (credit 1), that provide for a specified minimum air change effectiveness (credit 2), that prevent IAQ problems resulting from construction or renovation (credit 3), that prevent chemicals that adversely impact air quality from reaching occupants (credit 5), that provide for a high level of individual control by occupants (credits 6.1 and 6.2), that provide a thermally comfortable environment for occupants (credits 7.1 and 7.2), and that for using Daylighting and Views (credits 8.1 and 8.2).

## FOR MORE INFORMATION

Air Conditioning and Refrigeration Institute (ARI)  
Arlington, Virginia  
tel 703-524-8800  
web [www.ari.org](http://www.ari.org)

ARI publishes efficiency ratings in print and on CD-ROM for all certified air conditioners, heat pumps, and chillers. Efficiency ratings for selected products can be searched for on ARI's web site.

California Energy Commission  
Energy Efficiency Division  
Sacramento, California  
tel 916-654-5106  
web [www.energy.ca.gov/efficiency/index.html](http://www.energy.ca.gov/efficiency/index.html)

The California Energy Commission publishes standards regulating commercial building efficiency and maintains on its web site a list of unitary HVAC equipment that meets these standards.

Lawrence Berkeley National Laboratory  
Simulation Research Group  
Berkeley, California  
tel 510-486-5711  
web <http://gundog.lbl.gov>

Lawrence Berkeley National Laboratory's Simulation Research Group is the leading national organization researching and developing simulation tools for evaluating building energy performance. The group distributes a free newsletter for simulation users and operates a DOE-2 telephone help line.

Platts  
Boulder, Colorado  
tel 303-444-7788  
web [www.esource.platts.com](http://www.esource.platts.com)

Platts publishes *E SOURCE Technology Atlas Series, Volume II: Commercial Space Cooling and Air Handling* a comprehensive and definitive reference book that combines up-to-date technical information with practical case studies and application guidelines.

Pacific Energy Center  
San Francisco, California  
tel 415-973-2277  
web <http://www.pge.com/myhome/edusafety/workshopstraining/pec/>

The Pacific Energy Center is largely focused on central and northern California, and it provides a variety of services, including educational programs, design and measurement tools, technical advice, and energy information resources. It also offers several software tools for analyzing chillers and chilled water systems.

Southern California Edison  
Customer Technology Applications Center  
Irwindale, California  
tel 800-336-2822  
web <http://www.sce.com/b-sb/energy-centers/ctac/>

At this 45,000-ft<sup>2</sup> conference facility, visitors can learn about HVAC technologies by attending workshops, seminars, and product demonstrations.

## Notes

- 1 U.S. Department of Energy (DOE), Energy Information Administration, “Commercial Building Energy Consumption Survey” (1999), Table 1: End-Use Consumption for Natural Gas, Electricity and Fuel Oil (Preliminary Estimates),” from [www.eia.doe.gov/emeu/cbecs/enduse\\_consumption/intro.html](http://www.eia.doe.gov/emeu/cbecs/enduse_consumption/intro.html) (accessed August 2005).
- 2 Gary Cler et al., *E SOURCE Technology Atlas Series, Volume II: Commercial Space Cooling and Air Handling* (Boulder, CO: Platts, 1997), pp. 17–18.
- 3 W. Kempton and L. Lutzenhiser, “Introduction,” *Energy and Buildings*, v. 18, no. 3 (1992), pp. 171–176.
- 4 Alan Hedge, “Linking Environmental Conditions to Productivity,” abbreviated slideshow based on a presentation at the Eastern Ergonomics Conference and Exposition, New York (June 2004), from <http://ergo.human.cornell.edu/CUEHnews.html> (accessed July 2005).
- 5 Joseph Romm and William Browning, “Greening the Bottom Line,” Rocky Mountain Institute (1994), Old Snowmass, CO, 970-927-3851; “Get Comfortable,” *Facility Issues* (June 15, 1994); and Johnson Controls case study X95-241.
- 6 Terry Pederson (September 2005), Associate Product Manager, Johnson Controls, Milwaukee, WI, 414-524-4915, [terry.pederson@jci.com](mailto:terry.pederson@jci.com).
- 7 Alan Short (September 2005), Short and Associates, London, UK, +44-0-20-7407 8885, e-mail [post@short-assoc.demon.co.uk](mailto:post@short-assoc.demon.co.uk).
- 8 Susan Reily, Ira Krepchin, and Larry Kinney, “High-Performance Glazing in Commercial Buildings, Growing but Still Underused,” *E SOURCE Report, ER-01-16* (November 2001).
- 9 DOE, Energy Information Administration, “Commercial Building Energy Use Survey” (1995), Table 3: Electricity Consumption by End Use, from [www.eia.doe.gov/emeu/cbecs/cbec-eu3.html](http://www.eia.doe.gov/emeu/cbecs/cbec-eu3.html) (accessed July 2005).
- 10 Jay Stein, “Low-Cost/No-Cost Efficiency Retrofits for Chilled Water Systems,” *E SOURCE Tech Update, TU-97-9* (September 1997).

- 11 Gary Cler et al. [2], p. 98.
- 12 Ira Krepchin, "Underfloor Air Systems Gain Foothold in North America," *E SOURCE Report, ER-01-1* (January 2001).
- 13 Sharon Brogdon (September 2005), Trane, Tyler, TX, 903-581-3568, sharon.brogdon@trane.com.
- 14 DOE, Energy Information Administration, "Commercial Building Energy Use Survey" (1999), Table B29: Percent of Floorspace Cooled, Number of Buildings and Floorspace, from [www.eia.doe.gov/emeu/cbecs/pdf/alltables.pdf](http://www.eia.doe.gov/emeu/cbecs/pdf/alltables.pdf) (accessed July 2005).
- 15 ASHRAE (American Society of Heating, Refrigerating, and Air-Conditioning Engineers), *2007 ASHRAE Handbook: HVAC Applications, Chapter 32 (Table 8), p. 32.17*
- 16 DOE, Energy Information Administration, "Commercial Building Energy Use Survey" (1999) Table B7: Building Size, Floorspace, from [www.eia.doe.gov/emeu/cbecs/pdf/alltables.pdf](http://www.eia.doe.gov/emeu/cbecs/pdf/alltables.pdf) (accessed July 2005).
- 17 Assuming 1,500 annual equivalent full-load cooling hours and an electric rate of 10¢ per kilowatt hour.
- 18 DOE [16].
- 19 "2008 Joint Appendix JA2: Reference Weather / Climate Data," Title 24 Energy Efficiency Standards for Residential and Nonresidential Buildings (2008)
- 20 Tom Colvin, "Office Tower Reduces Operating Costs with Two-Stage Evaporative Cooling System," *ASHRAE Journal*, v. 37, no. 3 (March 1994), pp. 23–24.



Energy Design Resources provides information and design tools to architects, engineers, lighting designers, and building owners and developers. Energy Design Resources is funded by California utility customers and administered by Pacific Gas and Electric Co., Sacramento Municipal Utilities District, San Diego Gas and Electric, Southern California Edison, and Southern California Gas, under the auspices of the California Public Utilities Commission. To learn more about Energy Design Resources, please visit our web site at [www.energydesignresources.com](http://www.energydesignresources.com).

The first edition of this design brief was prepared for Energy Design Resources by the E SOURCE Technology Assessment Group at Platts, a Division of The McGraw-Hill Companies, Inc. Between January and April of 2010, an engineering review of this document was conducted to update passages affected by recent changes in the California Building Energy Efficiency Standards (Title 24 2008). The original content creator was not actively involved in this engineering review, and therefore is not responsible for the updates to the affected passages.